

1 SITE PLAN
1" = 30'-0"

C100 SITE PLAN

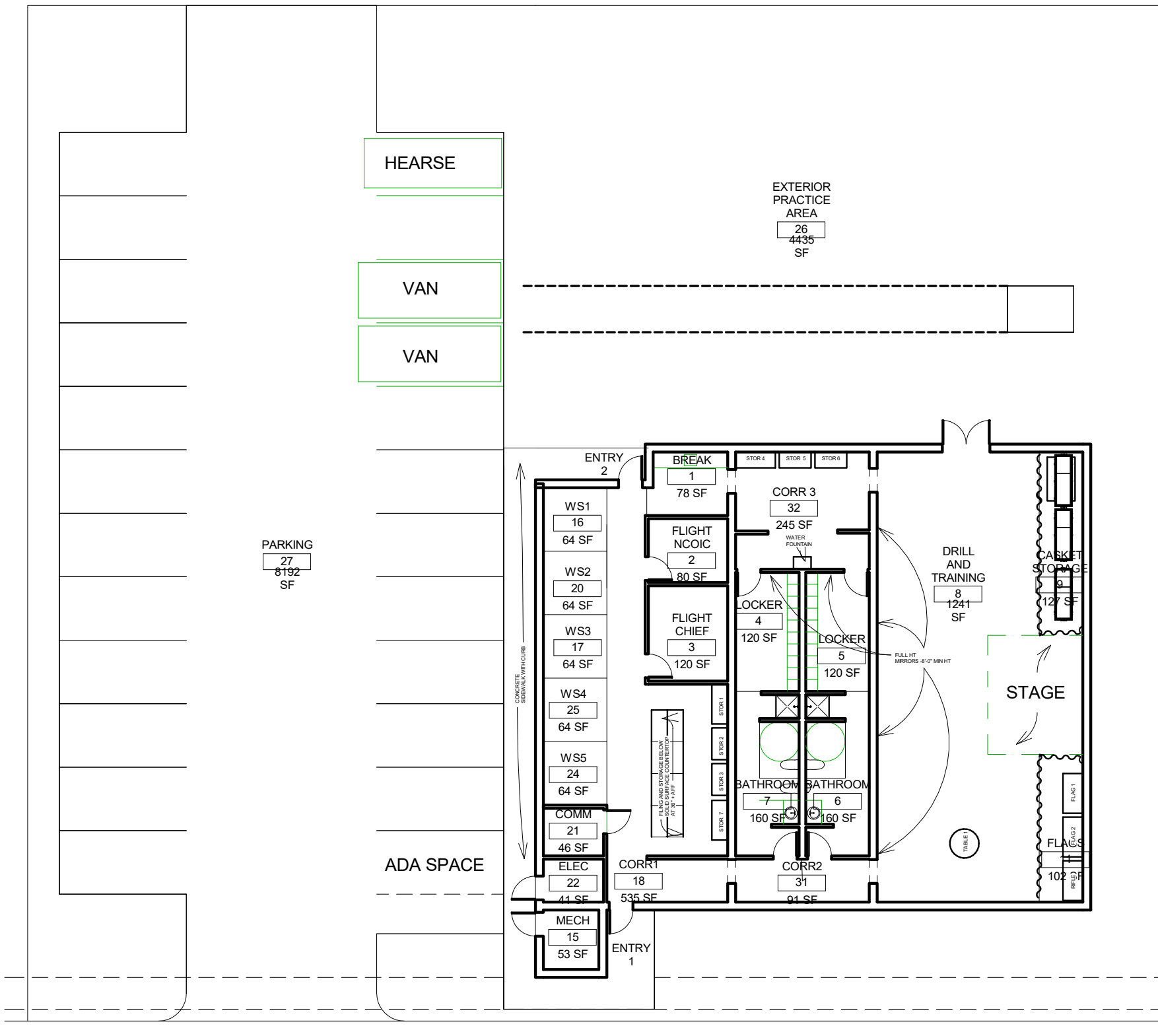

ROOM AREA SCHEDULE		
Name	Area	Number
BATHROOM	160 SF	6
BATHROOM	160 SF	7
BREAK	78 SF	1
CASKET STORAGE	127 SF	9
COMM	46 SF	21
CORR1	535 SF	18
CORR2	91 SF	31
CORR 3	245 SF	32
DRILL AND TRAINING	1241 SF	8
ELEC	41 SF	22
EXTERIOR PRACTICE AREA	4435 SF	26
FLAGS	102 SF	11
FLIGHT CHIEF	120 SF	3
FLIGHT NCOIC	80 SF	2
LOCKER	120 SF	4
LOCKER	120 SF	5
MECH	53 SF	15
PARKING	8192 SF	27
WS1	64 SF	16
WS2	64 SF	20
WS3	64 SF	17
WS4	64 SF	25
WS5	64 SF	24

16267 SF

1

HONOR GUARD FL PLAN

1/16" = 1'-0"

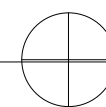

BUILDING FOOT PRINT 4200 SF APPROX

A101 FLOOR PLAN AND AREAS

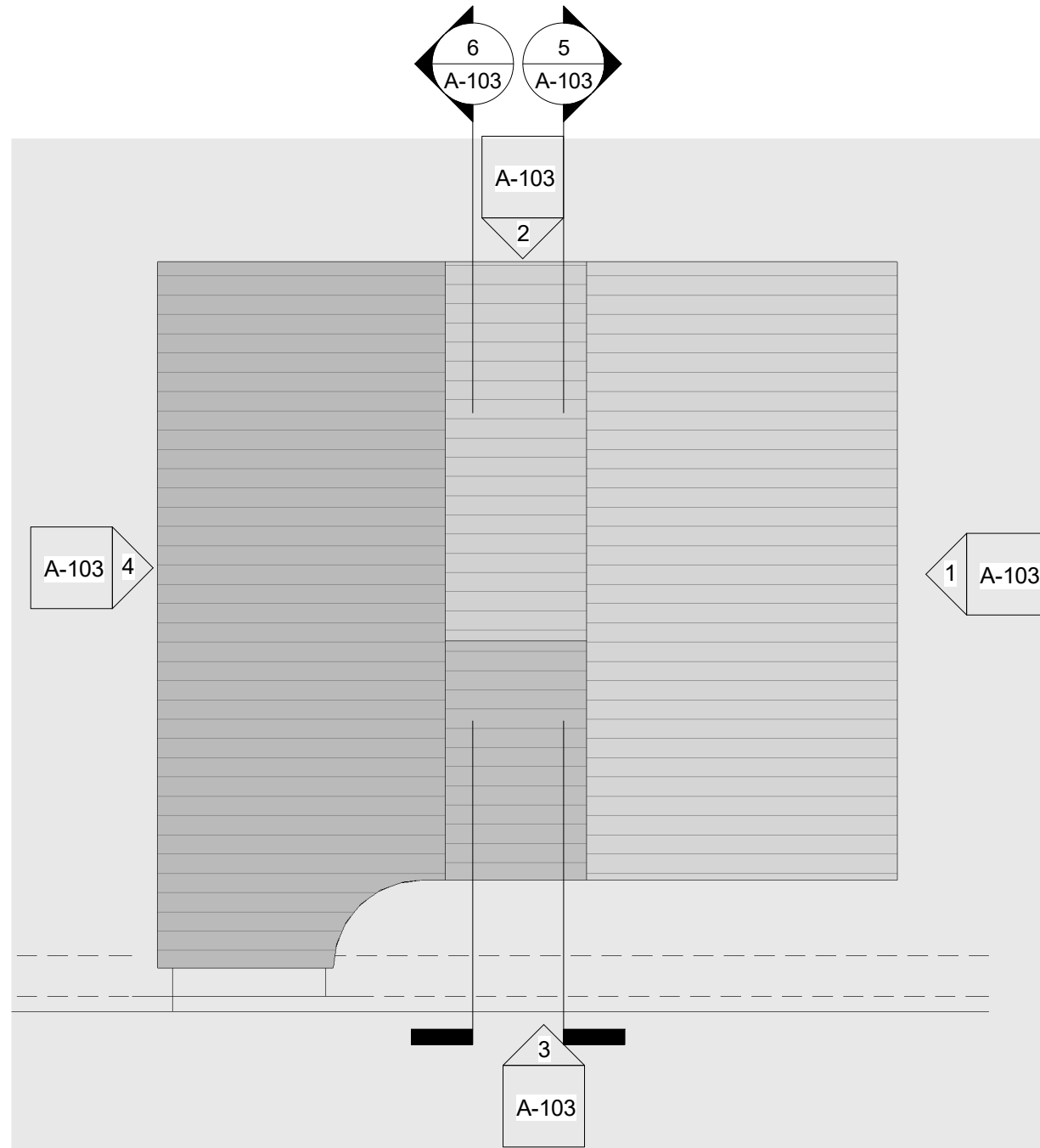

3 ROOF PLAN
1/16" = 1'-0"

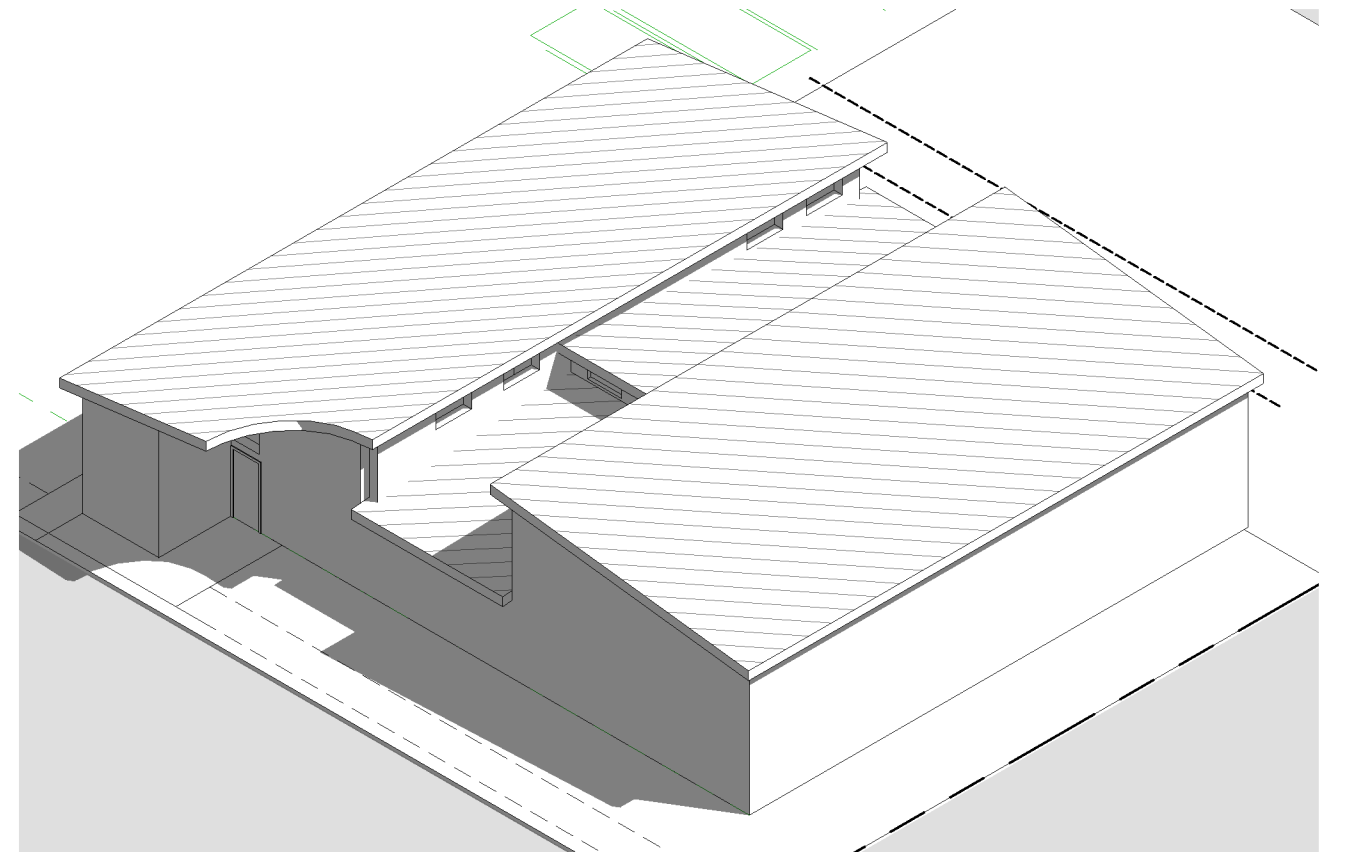

2 3D 2

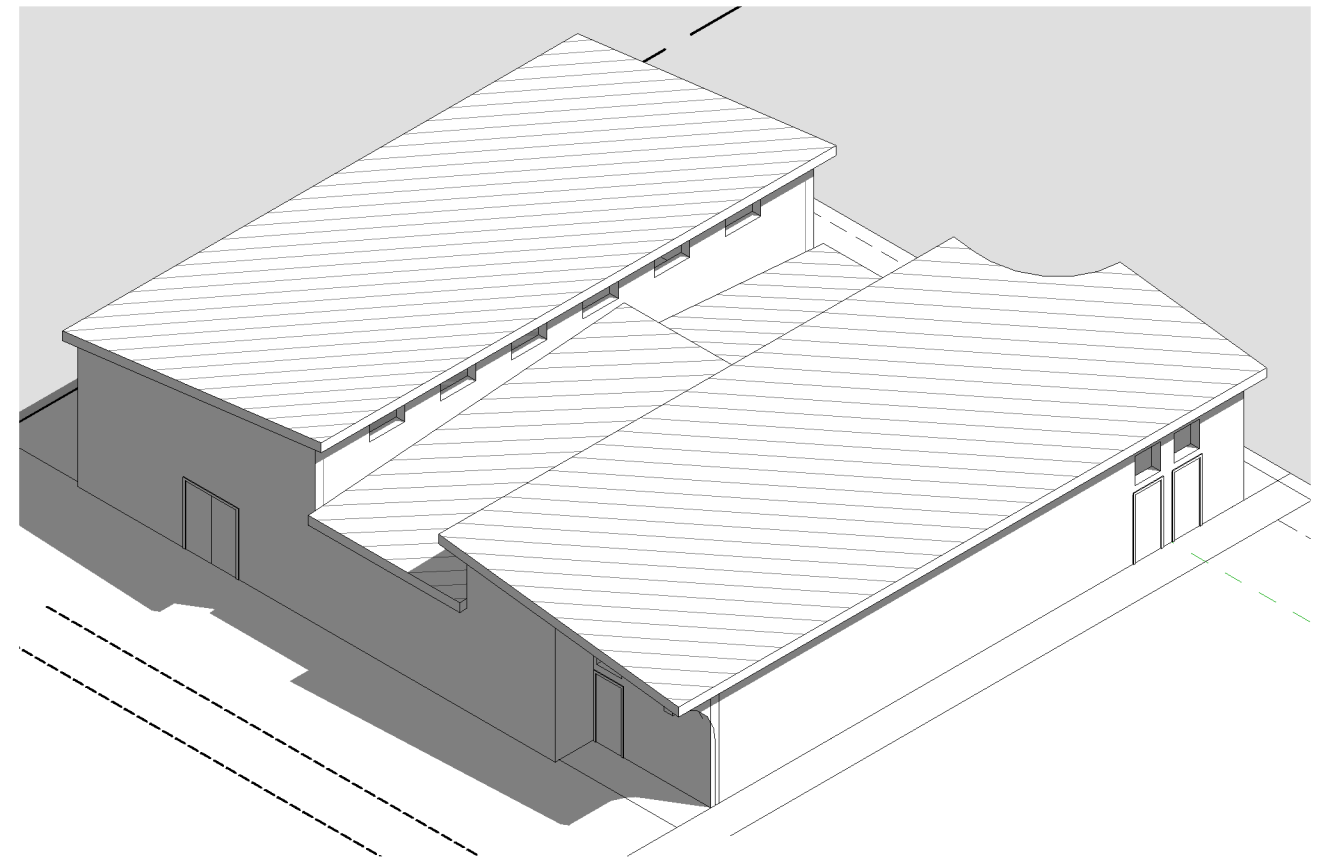

1 3D 1

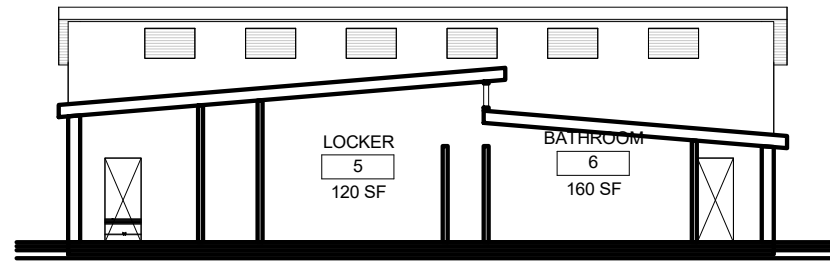

5 SECTION 01
1/16" = 1'-0"

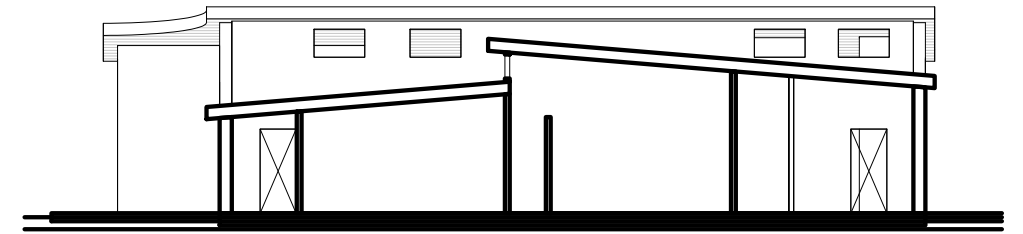

6 SECTION 02
1/16" = 1'-0"

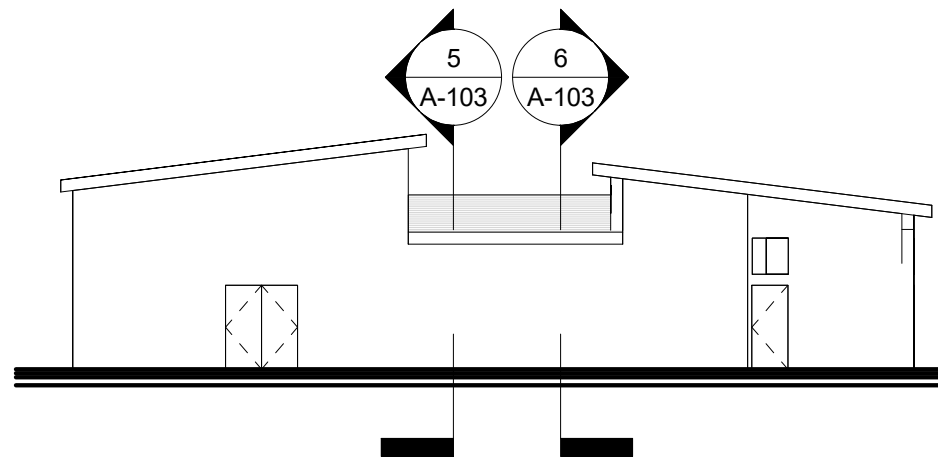

2 NORTH ELEVATION
1/16" = 1'-0"

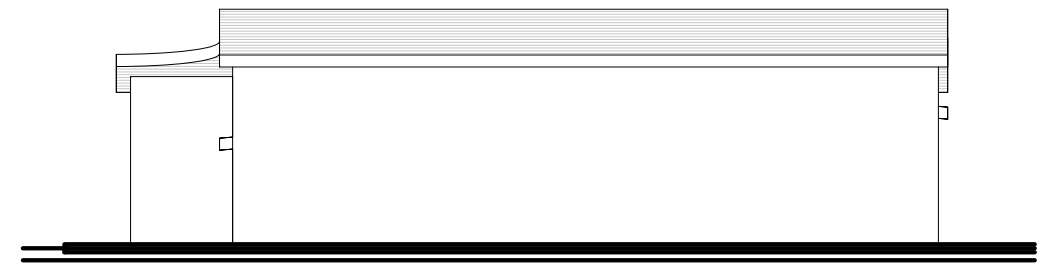

1 EAST ELEVATION
1/16" = 1'-0"

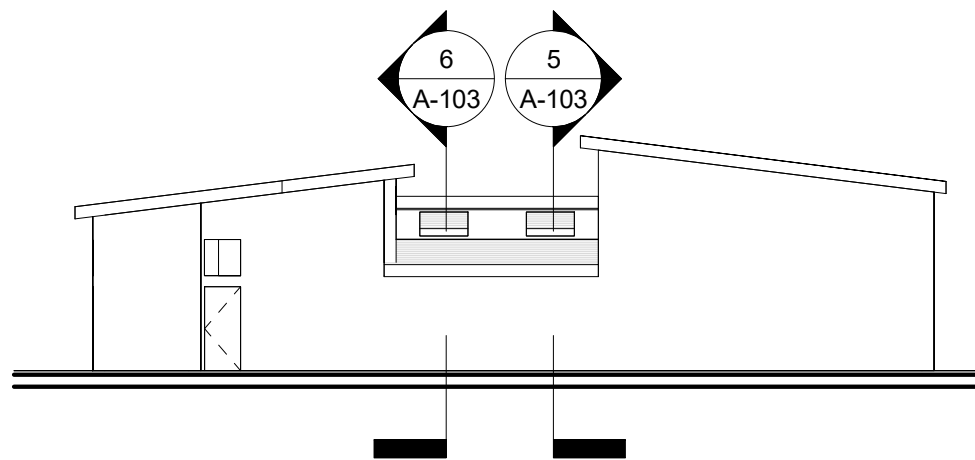

3 SOUTH ELEVATION
1/16" = 1'-0"

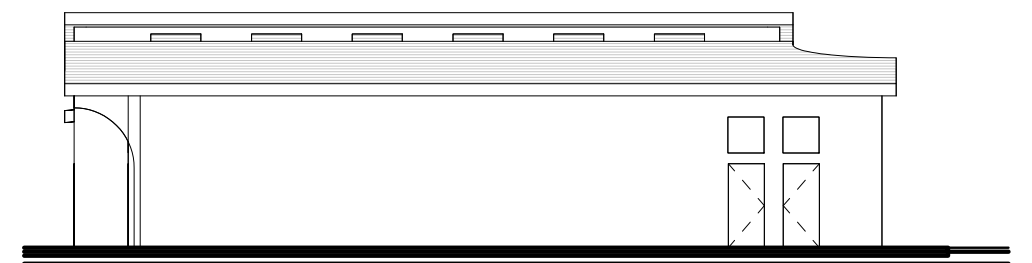

4 WEST ELEVATION
1/16" = 1'-0"